

Dust and Ash Conditioners

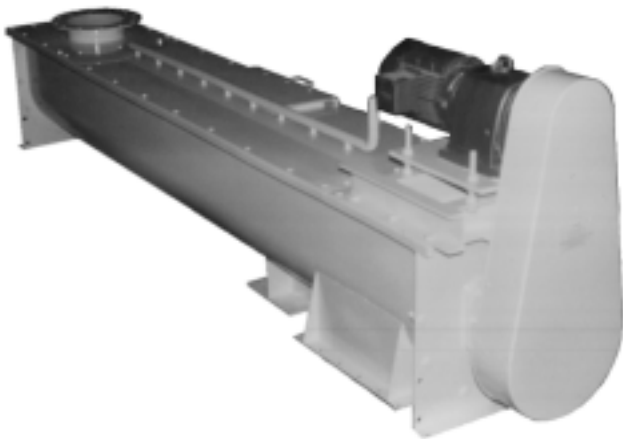

The Cleeve Materials Handling Limited range of Conditioners are designed to efficiently add moisture to dusty materials for safe handling and disposal.

Cleeve 
Materials Handling Limited

Suite 12, Lightpill Mill, Bath Road Trading Estate,
Stroud, Glos. GL5 3QF

Tel : 01453 750085 Fax : 01453 766776

Email : info@cleevemh.co.uk - Internet : <http://www.cleevemh.co.uk>

Dust and Ash Conditioners

The conditioners are designed to work on a continuous basis accepting a controlled feed of material from either a screw feeder, or rotary valve etc.

Paddle blade formation is set to give the most efficient mixing action with water being added by an arrangement of atomised spray nozzles up to 30% by weight.

All Conditioners are of heavy duty design, of single or twin shaft formation, material of construction can be mild steel or stainless steel.

Throughput rates depend upon the type and properties of the product being handled. Cleeve will specify the machine size, length, speed and power to suit the actual plant and capacity requirements.

The following information is required to enable a suitable machine to be specified :-

- a) Material to be handled.
- b) Bulk Density.
- c) Particle size range.
- d) Required throughput in Tonne/hour.
- e) Water Pressure available on Site.

Should your requirements be for more than a single machine Cleeve can provide you with a complete system, including storage, discharging handling and bulk outloading etc.

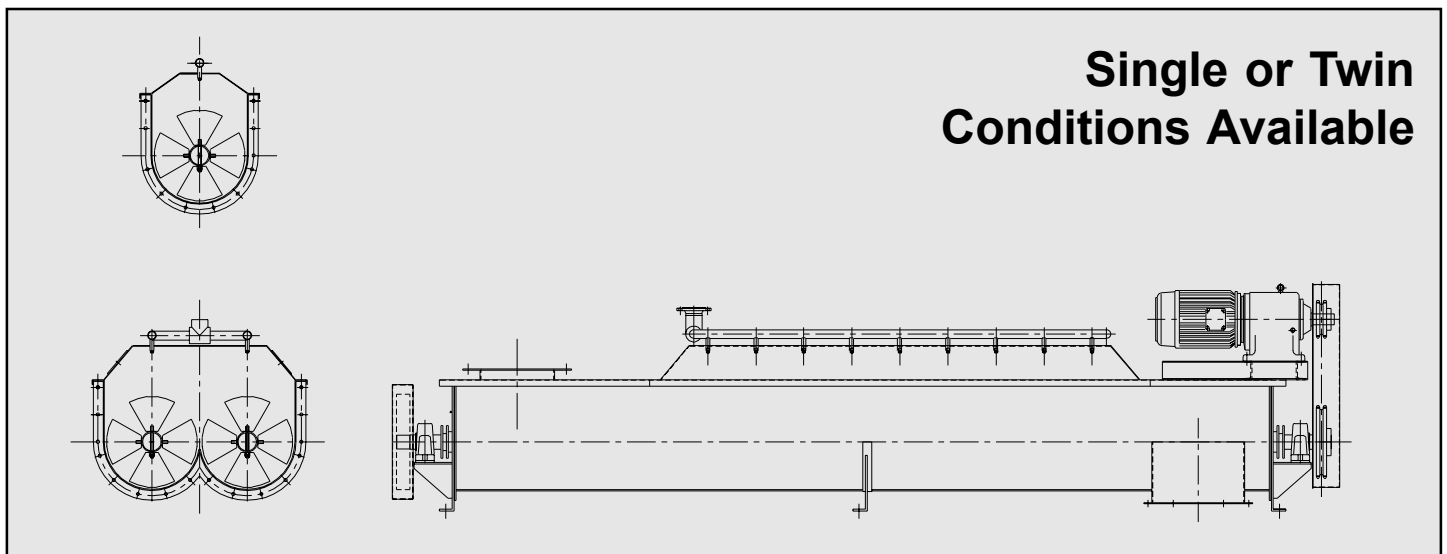

Other Products Supplied by Cleeve include

Bin Activators
Big Bag Discharge Station
Screw Conveyors and Feeders
Special Application Screw Conveyor

Bulk Loading Spouts
Silo Air Filters
Valves
Pneumatic Conveying Systems

Cleeve 
Materials Handling Limited

Suite 12, Lightpill Mill, Bath Road Trading Estate,
Stroud, Glos. GL5 3QF

Tel : 01453 750085 Fax : 01453 766776

Email : info@cleevemh.co.uk - Internet : <http://www.cleevemh.co.uk>