

Project Data Sheet

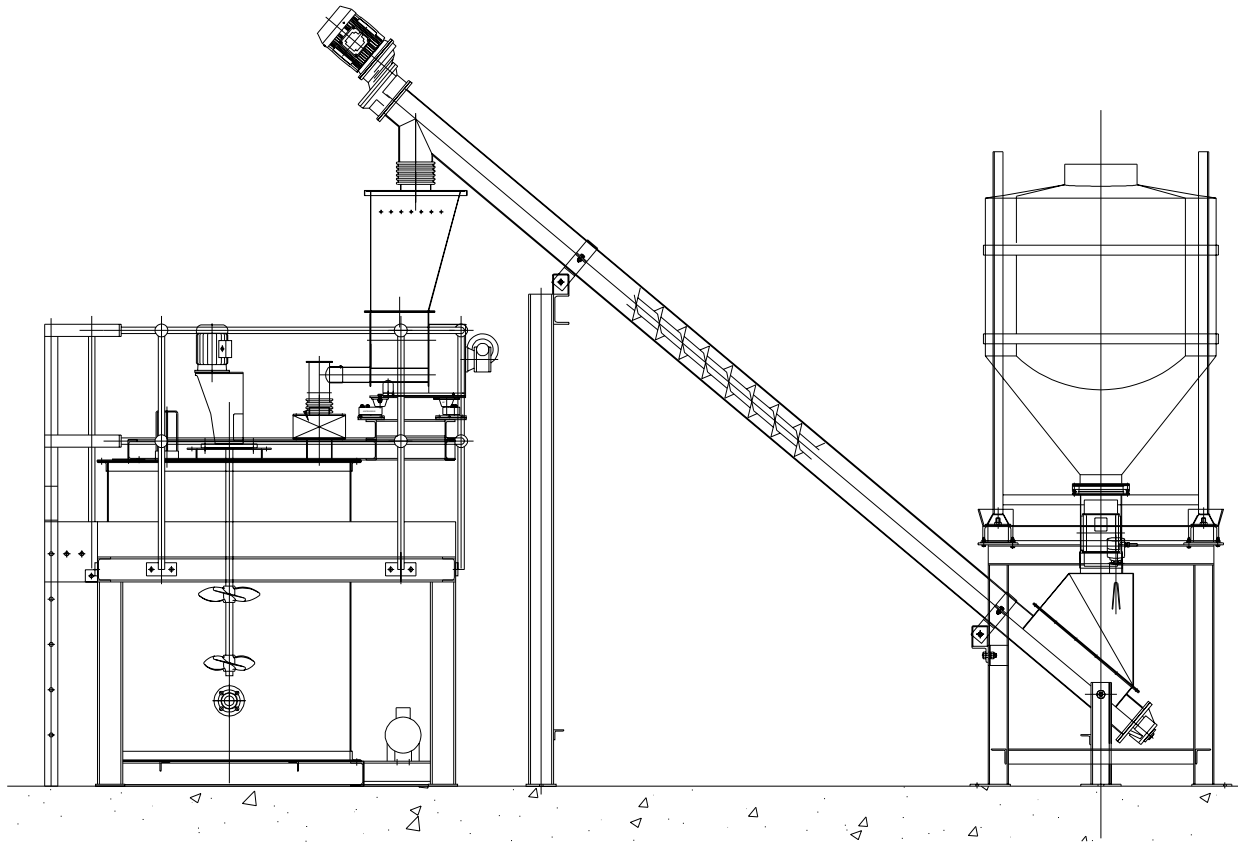

PAC Slurry Preparation Plant
Installed 2003 - Contract Value £52,000
Client: Degremont & Northumbrian Water

Technical Data		Plant Description
Storage	- Client's Tote Bin	Powder Activated Carbon is delivered in 1 tonne Tote Bins and is discharged by vibration.
Screw Conveyor	- 1 off 150 dia. tubular	The PAC is conveyed by screw conveyor to a loss-in-weight screw feeder which accurately feeds into the slurry mixing tank.
Loss-in-weight Feeder	- 1 off 60 dia. 100 litre capacity 304 stainless steel	Each tank is fitted with an ultrasonic level detector to control water levels and a liquid agitator unit to prepare the slurry.
Mixing Tank	- 1 off 1000 litre capacity 1200 dia. welded construction	

Cleeve 
MATERIALS HANDLING LIMITED

Suite 12, Lightpill Mill, Bath Road Trading Estate, Stroud, Glos. GL5 3QF
 Tel : 01453 750085 Fax : 01453 766776 Email : info@cleevemh.co.uk Web Site: <http://www.cleevemh.co.uk>